4 ALBERT EMBANKMENT
LONDON SE1 7SR
Telephone: +44 (0)20 7735 7611 Fax: +44 (0)20 7587 3210

MSC.1/Circ.1623
7 December 2020

**AMENDMENTS TO THE CODE OF
SAFE PRACTICE FOR CARGO STOWAGE AND SECURING (CSS CODE)**

1 The Maritime Safety Committee, at its 102nd session (4 to 11 November 2020), approved amendments to the *Code of Safe Practice for Cargo Stowage and Securing* (CSS Code), as prepared by the Sub-Committee on Carriage of Cargoes and Containers, at its sixth session (9 to 13 September 2019), as set out in the annex.

2 Member States are invited to bring the amendments to the attention of shipowners, ship operators, ship masters and crews and all parties concerned.

ANNEX

AMENDMENTS TO THE CODE OF SAFE PRACTICE FOR CARGO STOWAGE AND SECURING (CSS CODE)

ANNEX 13

*Methods to assess the efficiency of securing arrangements
For semi-standardized and non-standardized cargo*

The complete text of annex 13, together with its four appendices, is replaced by the following:

"1 Scope of application

1.1 The methods described in this annex should be applied to semi-standardized and non-standardized cargo including very heavy and/or very large cargo items. Standardized stowage and securing systems, in particular containers on containerhips, are excluded.

1.2 Cargoes carried on towed barges should be secured according to the provisions of this annex except that the assumed external forces may be determined using an alternative method acceptable to the Administration instead of that described in section 7.1 of this annex.

1.3 Very heavy and/or very large cargo items as addressed in chapter 1.8 of this Code may require provisions and considerations beyond the general scope of this annex. Examples of such provisions and considerations are given in appendix 3 of this annex.

1.4 Semi-standardized cargoes, for which the securing arrangements are often designed based on worst case assumptions on cargo properties, lashing angles and stowage positions on board, may require provisions and considerations beyond the general scope of this annex. Examples of such provisions and considerations are given in appendix 4 of this annex.

1.5 Notwithstanding the general principles contained in this annex, the adequacy of cargo securing may be demonstrated by means of detailed engineering calculations based upon the general principles and encompassing the additional provisions and considerations shown in appendix 3 of this annex. Computer programs used for that purpose should be validated against a suitable range of model tests or full-scale results in irregular seas. When using new software for new and unconventional applications, the validation should be documented.

1.6 The application of the methods described in this annex is supplementary to the principles of good seamanship and should not replace experience in stowage and securing practice.

2 Purpose of the methods

The methods should:

- .1 provide guidance for the preparation of Cargo Securing Manuals and the examples therein;
- .2 assist ship's staff in assessing the securing of cargo items not covered by the Cargo Securing Manual;

- .3 assist qualified shore personnel in assessing the securing of cargo items not covered by the Cargo Securing Manual; and
- .4 serve as a reference for maritime and port-related education and training.

3 Presentation of the methods

The methods are presented in a universally applicable and flexible way. It is recommended that designers of Cargo Securing Manuals convert this presentation into a format suiting the particular ship, its securing equipment and the cargo carried. This format may include applicable diagrams, tables or calculated examples.

4 Strength of securing equipment

4.1 Manufacturers of securing equipment should at least supply information on the nominal breaking strength of the equipment in kilonewtons (kN).¹

4.2 "Maximum securing load" (MSL) is a term used to define the load capacity for a device used to secure cargo to a ship. "Safe working load" (SWL) may be substituted for MSL for securing purposes, provided this is equal to or exceeds the strength defined by MSL.

Where practicable, the MSL should preferably be marked on the securing equipment.

The MSLs for different securing devices are given in table 1 if not given under 4.3.

The MSL of timber should be taken as 0.3 kN/cm² normal to the grain.

Table 1 – Determination of MSL from breaking strength

Material	MSL
Shackles, rings, deckeyes, turnbuckles of mild steel	50% of breaking strength
Fibre rope	33% of breaking strength
Web lashing	50% of breaking strength
Wire rope (single use)	80% of breaking strength
Wire rope (re-useable)	30% of breaking strength
Steel band (single use)	70% of breaking strength
Chains	50% of breaking strength

4.3 Particular securing devices (e.g. fibre straps with tensioners or special equipment for securing containers) may be marked with a permissible working load, as prescribed by an appropriate authority. This may be taken as the MSL.

4.4 When the components of a lashing device are connected in series (e.g. a wire to a shackle to a deckeye), the minimum MSL in the series should apply to that device.

4.5 Where temporary welded fittings are used, they should be designed to be adequate for the expected loading, and installed by qualified welders in accordance with established welding procedures. The design and placement of these fittings should be such as to minimize bending.

¹ 1 kN ≈ 100 kg.

4.6 Simple stoppers may be used to provide securing against sliding. These are generally welded to a surface by fillet welds, characterized by thickness (a) and length (l). A face plate should be provided against the cargo piece so that welds are not loaded by a shear force at right angles to the weld direction or by significant bending forces. As a simple rule of thumb for welded steel stoppers, the MSL of single-lay weld leg can then be approximated as 4 kN/cm (l) normal to the face plate, assuming 5 mm weld thickness (a). For a triple-lay weld leg, MSL can be taken as 10 kN/cm normal to the face plate.

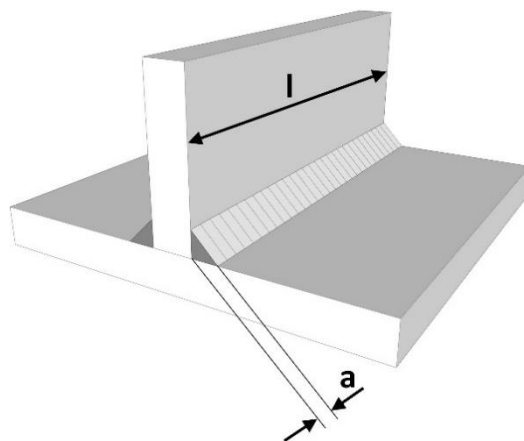

Figure 16.1 – Welding of steel stoppers

4.7 All securing devices to be accounted for in the balance calculations described in this annex should be capable of transferring forces directly from the vessel to the cargo or vice versa, in order to reflect their MSLs. For that purpose, lashings should be attached to fixed securing points or strong supporting structures marked on the cargo item or advised as being suitable, or taken as a loop around the item with both ends secured to the same side as shown in figure 7 in annex 5 of the Code. Lashings going over the top of the cargo item, whose only function is to increase friction by their pre-tension, cannot be credited in the evaluation of securing arrangements under this annex.

5 Rule-of-thumb method

5.1 The total of the MSL values of the securing devices on each side of a cargo item (port as well as starboard) should equal the weight of the item.²

5.2 This method, which implies a transverse acceleration of 1g (9.81 m/s²), applies to nearly any size of ship, regardless of the location of stowage, stability and loading condition, season and area of operation. The method, however, takes into account neither the adverse effects of lashing angles and non-homogeneous distribution of forces among the securing devices nor the favourable effect of friction.

5.3 Transverse lashing angles to the deck should not be greater than 60° and it is important that adequate friction is provided by the use of suitable material. Additional lashings at angles of greater than 60° may be desirable to prevent tipping but are not to be counted in the number of lashings under the rule of thumb.

6 Safety factor

6.1 When using balance calculation methods for assessing the strength of the securing devices, a safety factor is used to take account of the possibility of uneven distribution of forces among the devices or reduced capability due to the improper assembly of the devices or other

² The weight of the unit should be taken in kN.

reasons. This safety factor is used in the formula to derive the calculated strength (CS) from the MSL and shown in the relevant method used.

$$CS = \frac{MSL}{\text{safety factor}}$$

6.2 Notwithstanding the introduction of such a safety factor, care should be taken to use securing elements of similar material and length in order to provide a uniform elastic behaviour within the arrangement.

6.3 If securing devices of different elasticity are used in the same direction, e.g. welded bottom stoppers and fibre belts or long wire lashings, the more flexible securing devices in such an arrangement should be excluded if they, due to their elongation, do not contribute to preventing initial movement of the cargo.

7 Advanced calculation method

7.1 Assumption of external forces

7.1.1 External forces to a cargo item in longitudinal, transverse and vertical directions should be obtained using the formula:

$$F_{(x,y,z)} = m \cdot a_{(x,y,z)} + F_{w(x,y)} + F_{s(x,y)}$$

where

$F_{(x,y,z)}$ = longitudinal, transverse and vertical forces

m = mass of the item

$a_{(x,y,z)}$ = longitudinal, transverse and vertical accelerations
(see table 2 below)

$F_{w(x,y)}$ = longitudinal and transverse forces by wind pressure

$F_{s(x,y)}$ = longitudinal and transverse forces by sea sloshing.

The basic acceleration data are presented in table 2.

Table 2 – Basic acceleration data

Transverse acceleration a_y in m/s^2										Longitudinal acceleration a_x in m/s^2	
on deck, high	7.1	6.9	6.8	6.7	6.7	6.8	6.9	7.1	7.4	3.8	
on deck, low	6.5	6.3	6.1	6.1	6.1	6.1	6.3	6.5	6.7	2.9	
'tween-deck	5.9	5.6	5.5	5.4	5.4	5.5	5.6	5.9	6.2	2.0	
lower hold	5.5	5.3	5.1	5.0	5.0	5.1	5.3	5.5	5.9	1.5	
	0	0.1	0.2	0.3	0.4	0.5	0.6	0.7	0.8	0.9	L
Vertical acceleration a_z in m/s^2											
7.6 6.2 5.0 4.3 4.3 5.0 6.2 7.6 9.2											

Remarks:

The given transverse acceleration figures include components of gravity, pitch and heave parallel to the deck. The given vertical acceleration figures do not include the static weight component.

7.1.2 The basic acceleration data are to be considered as valid under the following operational conditions:³

- .1 operation in unrestricted area;
- .2 operation during the whole year;
- .3 length of ship is 100 m;
- .4 service speed is 15 knots; and
- .5 $B/GM \geq 13$ (B = moulded breadth of ship, GM = metacentric height).

7.1.3 For operation in a restricted area, reduction factors for accelerations may be considered, taking into account the season of the year, the accuracy of the weather forecast affecting the wave heights during the intended voyage and the duration of the voyage. Restricted area means any sea area in which the weather can be forecast for the entire sea voyage or shelter can be found during the voyage.

7.1.4 Reduction factors, f_R , may be applied to significant wave heights⁴, H_s , not exceeding 12 m for the design of securing arrangements in any of the following cases:

- .1 The required securing arrangement is calculated for the maximum expected 20-year significant wave height in a particular restricted area and the cargo is always secured according to the designed arrangement when operating in that area.
- .2 The maximum significant wave height that a particular securing arrangement can withstand is calculated and the vessel is limited to operating only in significant wave heights up to the maximum calculated. Procedures for ensuring that any operational limitation is not exceeded should be developed and followed and documented in the ship's approved Cargo Securing Manual.
- .3 Required securing arrangements are designed for different significant wave heights and the securing arrangement is selected according to the maximum expected wave height for each voyage for which an accurate weather forecast is available. Thus, the duration of the voyage should not exceed 72 hours or a duration as accepted by the Administration.

7.1.5 The basic acceleration data in table 2 may be multiplied by the following reduction factor:

$$f_R = 1 - (H_s - 13)^2 / 240, \text{ where } H_s \text{ is:}$$

- .1 the maximum expected 20-year significant wave height in the area according to ocean wave statistics; or
- .2 the maximum predicted significant wave height on which the operational limitations are based; or

³ The acceleration values in table 2 are calculated according to the guidance formulae for acceleration components in the IGC Code (resolution MSC.5(48)) and reduced to a probability level of 25 days.

⁴ Arithmetic mean of the highest one third of waves measured from trough to crest.

- .3 for voyages not exceeding 72 hours the maximum predicted significant wave height according to weather forecasts.

7.1.6 When weather-dependent lashing is applied, operational procedures for the following activities should be developed, followed and documented in the ship's approved Cargo Securing Manual, or otherwise included in the ship's safety management system:

- .1 decision on the level of cargo securing based on the length of the voyage and the weather forecast;
- .2 communication to all concerned parties of the decided level of cargo securing for the intended voyage;
- .3 execution and supervision of appropriate cargo securing efforts in accordance with the Cargo Securing Manual; and
- .4 monitoring of environmental conditions and ship motions to ensure that the applied level of cargo securing is not exceeded.

7.1.7 For ships of a length other than 100 m and a service speed other than 15 knots, the acceleration figures should be multiplied by a correction factor given in table 3.

Table 3 – Correction factors for length and service speed

Length (m) \ Speed (kn)	50	60	70	80	90	100	120	140	160	180	200
9	1.20	1.09	1.00	0.92	0.85	0.79	0.70	0.63	0.57	0.53	0.49
12	1.34	1.22	1.12	1.03	0.96	0.90	0.79	0.72	0.65	0.60	0.56
15	1.49	1.36	1.24	1.15	1.07	1.00	0.89	0.80	0.73	0.68	0.63
18	1.64	1.49	1.37	1.27	1.18	1.10	0.98	0.89	0.82	0.76	0.71
21	1.78	1.62	1.49	1.38	1.29	1.21	1.08	0.98	0.90	0.83	0.78
24	1.93	1.76	1.62	1.50	1.40	1.31	1.17	1.07	0.98	0.91	0.85

7.1.8 For length/speed combinations not directly tabulated, the following formula may be used to obtain the correction factor with v = speed in knots and L = length between perpendiculars in metres:

$$\text{correction factor} = (0.345 \cdot v / \sqrt{L}) + (58.62 \cdot L - 1034.5) / L^2$$

This formula should not be used for ship lengths less than 50 m or more than 300 m.

In addition, for ships with B/GM less than 13, the transverse acceleration figures should be multiplied by the correction factor given in table 4.

Table 4 – Correction factors for B/GM

B/GM	3	4	5	6	7	8	9	10	11	12	13 or above
on deck, high	2.64	2.28	1.98	1.74	1.56	1.40	1.27	1.19	1.11	1.05	1.00
on deck, low	2.18	1.93	1.72	1.55	1.42	1.30	1.21	1.14	1.09	1.04	1.00
'tween deck	1.62	1.51	1.41	1.33	1.26	1.19	1.14	1.09	1.06	1.03	1.00
lower hold	1.24	1.23	1.20	1.18	1.15	1.12	1.09	1.06	1.04	1.02	1.00

7.1.9 The following should be observed:

- .1 In the case of marked roll resonance with amplitudes above $\pm 30^\circ$, the given figures of transverse acceleration may be exceeded. Effective measures should be taken to avoid this condition.
- .2 In the case of heading into the seas at high speed with marked slamming impacts, the given figures of longitudinal and vertical acceleration may be exceeded. An appropriate reduction of speed should be considered.
- .3 In the case of running before large stern or quartering seas with a stability which does not amply exceed the accepted minimum requirements, large roll amplitudes must be expected with transverse accelerations greater than the figures given. An appropriate change of heading should be considered.
- .4 Forces by wind and sea to cargo items above the weather deck should be accounted for by a simple approach:
 - .1 force by wind pressure = 1 kN per m²
 - .2 force by sea sloshing = 1 kN per m²
- .5 The wind force may be reduced by the same principles as the accelerations, i.e. multiplying it with a reduction factor, f_R , based on the expected significant wave height.
- .6 Sloshing by sea can induce forces much greater than the figure given above. This figure should be considered as remaining unavoidable after adequate measures to prevent overcoming seas.
- .7 Sea sloshing forces need only be applied to a height of deck cargo up to 2 m above the weather deck or hatch top.
- .8 For voyages in a restricted area and with forecast wave heights for which no sea sloshing is expected, sea sloshing forces may be neglected.

7.2 Balance of forces and moments

7.2.1 The balance calculation should preferably be carried out for:

- .1 transverse sliding in port and starboard directions;
- .2 transverse tipping in port and starboard directions; and

- .3 longitudinal sliding under conditions of reduced friction in forward and aft directions.

7.2.2 In the case of symmetrical securing arrangements, one appropriate calculation for each case above is sufficient.

7.2.3 Friction contributes towards prevention of sliding. The following friction coefficients (μ) should be applied.

Table 5 – Friction coefficients

Materials in contact	Friction coefficient (μ)
Timber–timber, wet or dry	0.4
Steel–timber or steel–rubber	0.3
Steel–steel, dry	0.1
Steel–steel, wet	0.0

A friction increasing material or deck coating with higher friction coefficients may be used assuming a certified conservative friction coefficient and the endurable shear stress of the material under repeated loads, as they occur in heavy weather at sea. The applicability of these data should be reviewed with due consideration of the prevailing conditions in terms of moisture, dust, greasy dirt, frost, ice or snow as well as the local pressure applied (weight per area) to the material. Specific advice on this matter as well as instructions for maintenance of coatings should be included in the ship's Cargo Securing Manual, if appropriate.

7.2.4 Transverse sliding

7.2.4.1 The balance calculation should meet the following condition (see also figure 17):

$$F_y \leq \mu \cdot m \cdot g + CS_1 \cdot f_1 + CS_2 \cdot f_2 + \dots + CS_n \cdot f_n$$

Where:

n is the number of lashings being calculated

F_y is transverse force from load assumption (kN)

μ is friction coefficient

m is mass of the cargo item (t)

g is gravity acceleration of earth = 9.81 m/s²

CS is calculated strength of transverse securing devices (kN)

$$CS = \frac{MSL}{1.5}$$

f is a function of μ and the vertical securing angle α (see table 6).

7.2.4.2 A vertical securing angle α greater than 60° will reduce the effectiveness of this particular securing device in respect to sliding of the item. Disregarding of such devices from the balance of forces should be considered, unless the necessary load is gained by the imminent tendency to tipping or by a reliable pre-tensioning of the securing device and maintaining the pre-tension throughout the voyage.

7.2.4.3 Any horizontal securing angle, i.e. deviation from the transverse direction, should not exceed 30°, otherwise an exclusion of this securing device from the transverse sliding balance should be considered.

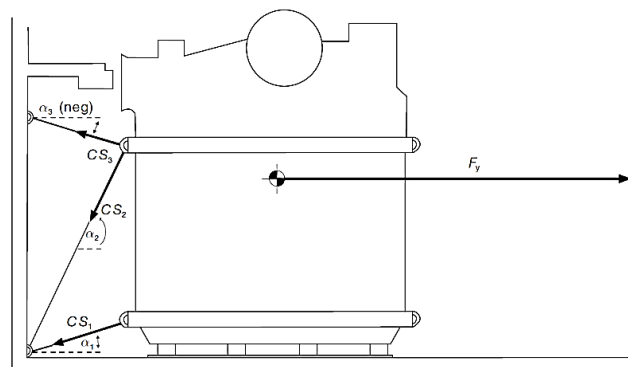

Figure 17 – Balance of transverse forces

Table 6 – f values as a function of α and μ

α \ μ	-30°	-20°	-10°	0°	10°	20°	30°	40°	50°	60°	70°	80°	90°
0.3	0.72	0.84	0.93	1.00	1.04	1.04	1.02	0.96	0.87	0.76	0.62	0.47	0.30
0.1	0.82	0.91	0.97	1.00	1.00	0.97	0.92	0.83	0.72	0.59	0.44	0.27	0.10
0.0	0.87	0.94	0.98	1.00	0.98	0.94	0.87	0.77	0.64	0.50	0.34	0.17	0.00

Remark: $f = \mu \cdot \sin \alpha + \cos \alpha$

7.2.4.4 As an alternative to using table 6 to determine the forces in a securing arrangement, the method outlined in paragraph 7.3 can be used to take account of transverse and longitudinal components of lashing forces.

7.2.5 Transverse tipping

This balance calculation should meet the following condition (see also figure 18):

$$F_y \cdot a \leq b \cdot m \cdot g + CS_1 \cdot c_1 + CS_2 \cdot c_2 + \dots + CS_n \cdot c_n$$

where

F_y , m , g , CS , n are as explained under 7.2.1

- a is lever-arm of tipping (m) (see figure 18)
- b is lever-arm of stableness (m) (see figure 18)
- c is lever-arm of securing force (m) (see figure 18)

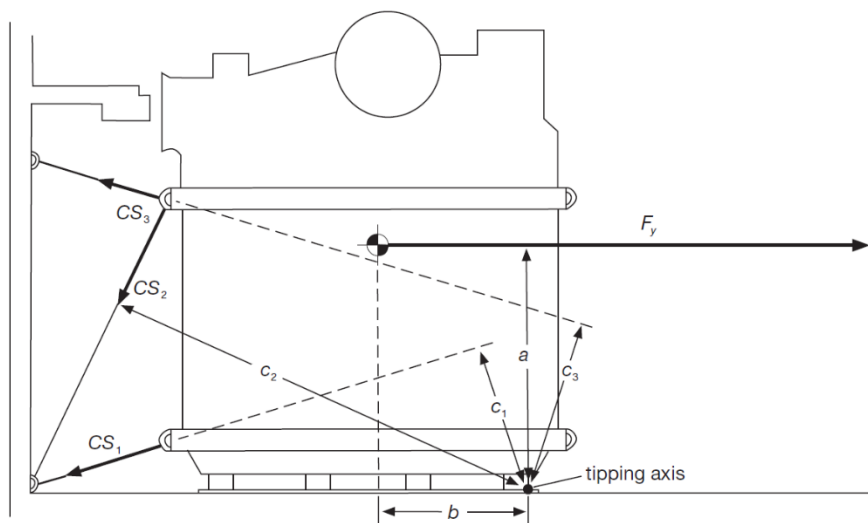

Figure 18 – Balance of transverse moments

7.2.6 Longitudinal sliding

7.2.6.1 Under normal conditions the transverse securing devices provide sufficient longitudinal components to prevent longitudinal sliding. If in doubt, a balance calculation should meet the following condition:

$$F_x \leq \mu \cdot (m \cdot g - f_z \cdot F_z) + CS_1 \cdot f_1 + CS_2 \cdot f_2 + \dots + CS_n \cdot f_n$$

where

F_x is longitudinal force from load assumption (kN)

μ , m , g , f , n are as explained under 7.2.1

F_z is vertical force from load assumption (kN)

f_z is a correction factor for the vertical force, depending on friction as indicated below:

μ	0.0	0.1	0.2	0.3	0.4	0.6
f_z	0.20	0.50	0.70	0.80	0.85	0.90

7.2.6.2 CS is calculated strength of longitudinal securing devices (kN)

$$CS = \frac{MSL}{1.5}$$

Remark: Longitudinal components of transverse securing devices should not be assumed greater than $0.5 \cdot CS$.

7.2.6.3 Instead of service speed, a reduced operational speed is allowed to be used when the correction factor for length and speed is calculated according to table 3 for the correction of the longitudinal and vertical accelerations. The longitudinal acceleration calculated using table 3 in this annex should be verified by monitoring during the voyage. When necessary the speed should be further reduced in order to ensure that the calculated acceleration is not exceeded. In the Cargo Securing Manual, it should be noted that the speed has to be reduced in heavy head seas to avoid longitudinal shifting of cargo. It should also be noted for which speed the accelerations in longitudinal direction have been calculated.

Note: Correction factors for speeds less than the service speed are not allowed for the correction of transverse accelerations.

7.2.7 Calculated example

A calculated example for this method is shown in appendix 1 of annex 13.

7.3 Balance of forces – alternative method

7.3.1 The balance of forces described in paragraph 7.2.4 and 7.2.6 will normally furnish a sufficiently accurate determination of the adequacy of the securing arrangement. However, this alternative method allows a more precise consideration of horizontal securing angles.

7.3.2 Securing devices usually do not have a pure longitudinal or transverse direction in practice but have an angle β in the horizontal plane. This horizontal securing angle β is defined in this annex as the angle of deviation from the transverse direction. The angle β is to be scaled in the quadrantal mode, i.e. between 0° and 90° .

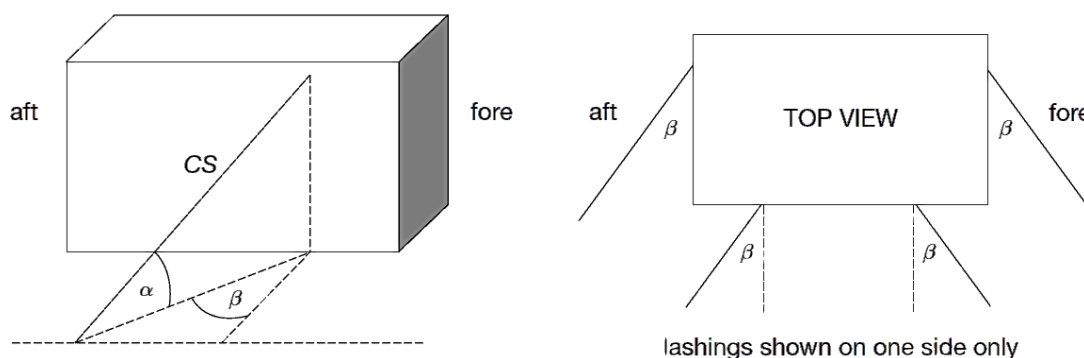

Figure 19 – Definition of the vertical and horizontal securing angles α and β

7.3.3 A securing device with an angle β develops securing effects both in longitudinal and transverse direction, which can be expressed by multiplying the calculated strength CS with the appropriate values of f_x or f_y . The values of f_x and f_y can be obtained from table 7.

7.3.4 Table 7 consists of five sets of figures, one each for the friction coefficients $\mu = 0.4, 0.3, 0.2, 0.1$ and 0 . Each set of figures is obtained by using the vertical angle α and horizontal angle β . The value of f_x is obtained when entering the table with β from the right while f_y is obtained when entering with β from the left, using the nearest tabular value for α and β . Interpolation is not required but may be used.

The balance calculations are made in accordance with the following formulae:

$$\text{Transverse sliding: } F_y \leq \mu \cdot m \cdot g + f_{y1} \cdot CS_1 + \dots + f_{yn} \cdot CS_n$$

$$\text{Longitudinal sliding: } F_x \leq \mu \cdot (m \cdot g - f_z \cdot F_z) + f_{x1} \cdot CS_1 + \dots + f_{xn} \cdot CS_n$$

$$\text{Transverse tipping: } F_y \cdot a \leq b \cdot m \cdot g + 0.9 \cdot (CS_1 \cdot c_1 + CS_2 \cdot c_2 + \dots + CS_n \cdot c_n)$$

Caution:

Securing devices which have a vertical angle α of less than 45° in combination with horizontal angle β greater than 45° should not be used in the balance of transverse tipping in the above

formula. All symbols used in these formulae have the same meaning as defined in paragraph 7.2 except f_y and f_x , obtained from table 7, and CS is as follows:

$$CS = \frac{MSL}{1.35}$$

A calculated example for this method is shown in appendix 1 of annex 13.

Table 7 – f_x values and f_y values as a function of α , β and μ

Table 7.1 for $\mu = 0.4$

β for f_y	α														β for f_x
	-30	-20	-10	0	10	20	30	40	45	50	60	70	80	90	
0	0.67	0.80	0.92	1.00	1.05	1.08	1.07	1.02	0.99	0.95	0.85	0.72	0.57	0.40	90
10	0.65	0.79	0.90	0.98	1.04	1.06	1.05	1.01	0.98	0.94	0.84	0.71	0.56	0.40	80
20	0.61	0.75	0.86	0.94	0.99	1.02	1.01	0.98	0.95	0.91	0.82	0.70	0.56	0.40	70
30	0.55	0.68	0.78	0.87	0.92	0.95	0.95	0.92	0.90	0.86	0.78	0.67	0.54	0.40	60
40	0.46	0.58	0.68	0.77	0.82	0.86	0.86	0.84	0.82	0.80	0.73	0.64	0.53	0.40	50
50	0.36	0.47	0.56	0.64	0.70	0.74	0.76	0.75	0.74	0.72	0.67	0.60	0.51	0.40	40
60	0.23	0.33	0.42	0.50	0.56	0.61	0.63	0.64	0.64	0.63	0.60	0.55	0.48	0.40	30
70	0.10	0.18	0.27	0.34	0.41	0.46	0.50	0.52	0.52	0.53	0.52	0.49	0.45	0.40	20
80	-0.05	0.03	0.10	0.17	0.24	0.30	0.35	0.39	0.41	0.42	0.43	0.44	0.42	0.40	10
90	-0.20	-0.14	-0.07	0.00	0.07	0.14	0.20	0.26	0.28	0.31	0.35	0.38	0.39	0.40	0

Table 7.2 for $\mu = 0.3$

β for f_y	A														β for f_x
	-30	-20	-10	0	10	20	30	40	45	50	60	70	80	90	
0	0.72	0.84	0.93	1.00	1.04	1.04	1.02	0.96	0.92	0.87	0.76	0.62	0.47	0.30	90
10	0.70	0.82	0.92	0.98	1.02	1.03	1.00	0.95	0.91	0.86	0.75	0.62	0.47	0.30	80
20	0.66	0.78	0.87	0.94	0.98	0.99	0.96	0.91	0.88	0.83	0.73	0.60	0.46	0.30	70
30	0.60	0.71	0.80	0.87	0.90	0.92	0.90	0.86	0.82	0.79	0.69	0.58	0.45	0.30	60
40	0.51	0.62	0.70	0.77	0.81	0.82	0.81	0.78	0.75	0.72	0.64	0.54	0.43	0.30	50
50	0.41	0.50	0.58	0.64	0.69	0.71	0.71	0.69	0.67	0.64	0.58	0.50	0.41	0.30	40
60	0.28	0.37	0.44	0.50	0.54	0.57	0.58	0.58	0.57	0.55	0.51	0.45	0.38	0.30	30
70	0.15	0.22	0.28	0.34	0.39	0.42	0.45	0.45	0.45	0.45	0.43	0.40	0.35	0.30	20
80	0.00	0.06	0.12	0.17	0.22	0.27	0.30	0.33	0.33	0.34	0.35	0.34	0.33	0.30	10
90	-0.15	-0.10	-0.05	0.00	0.05	0.10	0.15	0.19	0.21	0.23	0.26	0.28	0.30	0.30	0

Table 7.3 for $\mu = 0.2$

β for f_y	A														β for f_x
	-30	-20	-10	0	10	20	30	40	45	50	60	70	80	90	
0	0.77	0.87	0.95	1.00	1.02	1.01	0.97	0.89	0.85	0.80	0.67	0.53	0.37	0.20	90
10	0.75	0.86	0.94	0.98	1.00	0.99	0.95	0.88	0.84	0.79	0.67	0.52	0.37	0.20	80
20	0.71	0.81	0.89	0.94	0.96	0.95	0.91	0.85	0.81	0.76	0.64	0.51	0.36	0.20	70
30	0.65	0.75	0.82	0.87	0.89	0.88	0.85	0.79	0.75	0.71	0.61	0.48	0.35	0.20	60
40	0.56	0.65	0.72	0.77	0.79	0.79	0.76	0.72	0.68	0.65	0.56	0.45	0.33	0.20	50
50	0.46	0.54	0.60	0.64	0.67	0.67	0.66	0.62	0.60	0.57	0.49	0.41	0.31	0.20	40
60	0.33	0.40	0.46	0.50	0.53	0.54	0.53	0.51	0.49	0.47	0.42	0.36	0.28	0.20	30

β for f_y	A														β for f_x
	-30	-20	-10	0	10	20	30	40	45	50	60	70	80	90	
70	0.20	0.25	0.30	0.34	0.37	0.39	0.40	0.39	0.38	0.37	0.34	0.30	0.26	0.20	20
80	0.05	0.09	0.14	0.17	0.21	0.23	0.25	0.26	0.26	0.26	0.26	0.25	0.23	0.20	10
90	-	-	-	0.00	0.03	0.07	0.10	0.13	0.14	0.15	0.17	0.19	0.20	0.20	0

Table 7.4 for $\mu = 0.1$

β for f_y	A														β for f_x
	-30	-20	-10	0	10	20	30	40	45	50	60	70	80	90	
0	0.82	0.91	0.97	1.00	1.00	0.97	0.92	0.83	0.78	0.72	0.59	0.44	0.27	0.10	90
10	0.80	0.89	0.95	0.98	0.99	0.96	0.90	0.82	0.77	0.71	0.58	0.43	0.27	0.10	80
20	0.76	0.85	0.91	0.94	0.94	0.92	0.86	0.78	0.74	0.68	0.56	0.42	0.26	0.10	70
30	0.70	0.78	0.84	0.87	0.87	0.85	0.80	0.73	0.68	0.63	0.52	0.39	0.25	0.10	60
40	0.61	0.69	0.74	0.77	0.77	0.75	0.71	0.65	0.61	0.57	0.47	0.36	0.23	0.10	50
50	0.51	0.57	0.62	0.64	0.65	0.64	0.61	0.56	0.53	0.49	0.41	0.31	0.21	0.10	40
60	0.38	0.44	0.48	0.50	0.51	0.50	0.48	0.45	0.42	0.40	0.34	0.26	0.19	0.10	30
70	0.25	0.29	0.32	0.34	0.35	0.36	0.35	0.33	0.31	0.30	0.26	0.21	0.16	0.10	20
80	0.10	0.13	0.15	0.17	0.19	0.20	0.20	0.20	0.19	0.19	0.17	0.15	0.13	0.10	10
90	-0.05	-0.03	-0.02	0.00	0.02	0.03	0.05	0.06	0.07	0.08	0.09	0.09	0.10	0.10	0

Table 7.5 for $\mu = 0.0$

β for f_y	A														β for f_x
	-30	-20	-10	0	10	20	30	40	45	50	60	70	80	90	
0	0.87	0.94	0.98	1.00	0.98	0.94	0.87	0.77	0.71	0.64	0.50	0.34	0.17	0.00	90
10	0.85	0.93	0.97	0.98	0.97	0.93	0.85	0.75	0.70	0.63	0.49	0.34	0.17	0.00	80
20	0.81	0.88	0.93	0.94	0.93	0.88	0.81	0.72	0.66	0.60	0.47	0.32	0.16	0.00	70
30	0.75	0.81	0.85	0.87	0.85	0.81	0.75	0.66	0.61	0.56	0.43	0.30	0.15	0.00	60
40	0.66	0.72	0.75	0.77	0.75	0.72	0.66	0.59	0.54	0.49	0.38	0.26	0.13	0.00	50
50	0.56	0.60	0.63	0.64	0.63	0.60	0.56	0.49	0.45	0.41	0.32	0.22	0.11	0.00	40
60	0.43	0.47	0.49	0.50	0.49	0.47	0.43	0.38	0.35	0.32	0.25	0.17	0.09	0.00	30
70	0.30	0.32	0.34	0.34	0.34	0.32	0.30	0.26	0.24	0.22	0.17	0.12	0.06	0.00	20
80	0.15	0.16	0.17	0.17	0.17	0.16	0.15	0.13	0.12	0.11	0.09	0.06	0.03	0.00	10
90	0.00	0.00	0.00	0.00	0.00	0.00	0.00	0.00	0.00	0.00	0.00	0.00	0.00	0.00	0

Remark: $f_y = \cos \alpha \cdot \cos \beta + \mu \cdot \sin \alpha$ $f_x = \cos \alpha \cdot \sin \beta + \mu \cdot \sin \alpha$.

APPENDIX 1

CALCULATED EXAMPLE 1

(refer to paragraph 7.2, Balance of forces and moments)

Ship: $L = 120\text{ m}$; $B = 20\text{ m}$; $GM = 1.4\text{ m}$; speed = 15 knots
Cargo: $m = 62\text{ t}$; dimensions = $6 \times 4 \times 4\text{ m}$;
stowage at $0.7L$ on deck, low

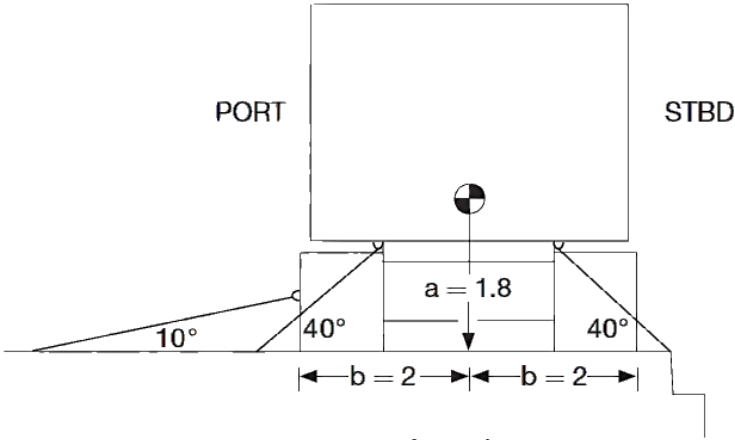
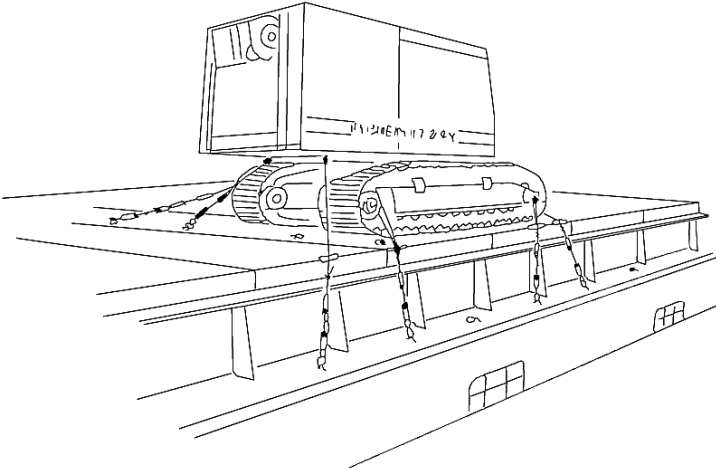

front view

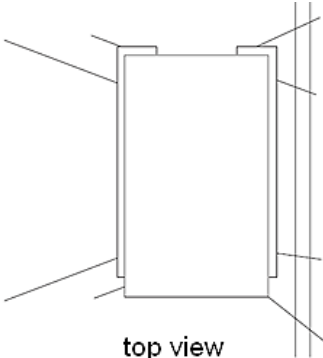

top view

Securing material:

wire rope (single use): breaking strength = 125 kN; *MSL* = 100 kN
 shackles, turnbuckles, deck rings: breaking strength = 180 kN; *MSL* = 90 kN
 stowage on dunnage boards: $\mu = 0.3$; $CS = 90/1.5 = 60$ kN

Securing arrangement:

side	<i>n</i>	CS	α	<i>f</i>	<i>c</i>
STBD	4	60 kN	40°	0.96	–
PORT	2	60 kN	40°	0.96	–
PORT	2	60 kN	10°	1.04	–

External forces:

$$F_x = 2.9 \times 0.89 \times 62 + 16 + 8 = 184 \text{ kN}$$

$$F_y = 6.3 \times 0.89 \times 62 + 24 + 12 = 384 \text{ kN}$$

$$F_z = 6.2 \times 0.89 \times 62 = 342 \text{ kN}$$

Balance of forces (STBD arrangement):

$$384 < 0.3 \times 62 \times 9.81 + 4 \times 60 \times 0.96$$

$$384 < 412 \text{ this is OK!}$$

Balance of forces (PORT arrangement):

$$384 < 0.3 \times 62 \times 9.81 + 2 \times 60 \times 0.96 + 2 \times 60 \times 1.04$$

$$384 < 422 \text{ this is OK!}$$

Balance of moments:

$$384 \times 1.8 < 2 \times 62 \times 9.81$$

$$691 < 1216 \text{ no tipping, even without lashings!}$$

Calculated example 2

(refer to section 7.3, Balance of forces – alternative method)

A cargo item of 68 t mass is stowed on timber ($\mu = 0.3$) in the 'tween deck at $0.7L$ of a vessel.
 $L = 160$ m, $B = 24$ m, $v = 18$ knots and $GM = 1.5$ m.
 Dimensions of the cargo item are height = 2.4 m and width = 1.8 m.
 The external forces are: $F_x = 112$ kN, $F_y = 312$ kN, $F_z = 346$ kN, $f_z = 0.8$ and $f_z' F_z = 276.8$ kN

The top view shows the overall securing arrangement with eight lashings.

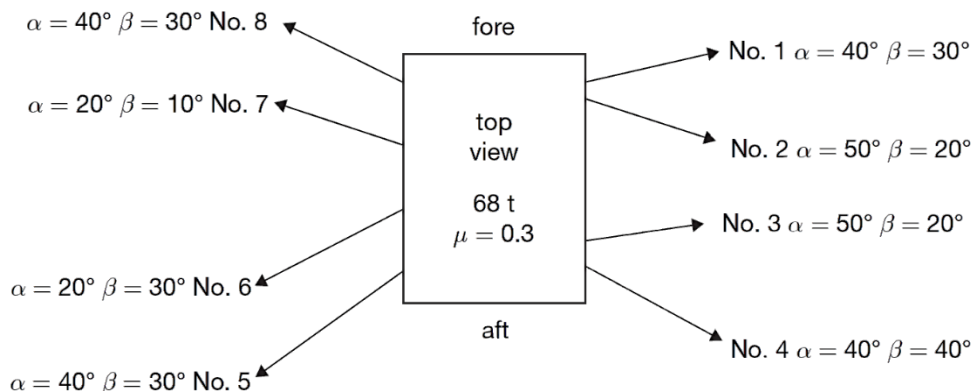

Calculation of balance of forces:

No.	MSL (kN)	CS (kN)	α	β	f_y	CS × f_y	f_x	CS × f_x
1	108	80	40° stbd	30° fwd	0.86	68.8 stbd	0.58	46.4 fwd
2	90	67	50° stbd	20° aft	0.83	55.6 stbd	0.45	30.2 aft
3	90	67	50° stbd	20° fwd	0.83	55.6 stbd	0.45	30.2 fwd
4	108	80	40° stbd	40° aft	0.78	62.4 stbd	0.69	55.2 aft
5	108	80	40° port	30° aft	0.86	68.8 port	0.58	46.4 aft
6	90	67	20° port	30° aft	0.92	61.6 port	0.57	38.2 aft
7	90	67	20° port	10° fwd	1.03	69.0 port	0.27	18.1 fwd
8	108	80	40° port	30° fwd	0.86	68.8 port	0.58	46.4 fwd

Transverse balance of forces (STBD arrangement) Nos. 1, 2, 3 and 4:

$$312 < 0.3 \times 68 \times 9.81 + 68.8 + 55.6 + 55.6 + 62.4$$

312 < 443 this is OK!

Transverse balance of forces (PORT arrangement) Nos. 5, 6, 7 and 8:

$$312 < 0.3 \times 68 \times 9.81 + 68.8 + 61.6 + 69.0 + 68.8$$

312 < 468 this is OK!

Longitudinal balance of forces (FWD arrangement) Nos. 1, 3, 7 and 8:

$$112 < 0.3 (68 \times 9.81 - 276.8) + 46.4 + 30.2 + 18.1 + 46.4$$

112 < 258 this is OK!

Longitudinal balance of forces (AFT arrangement) Nos. 2, 4, 5 and 6:

$$112 < 0.3 (68 \times 9.81 - 276.8) + 30.2 + 55.2 + 46.4 + 38.2$$

112 < 287 this is OK!

Transverse tipping

Unless specific information is provided, the vertical centre of gravity of the cargo item can be assumed to be at one half the height and the transverse centre of gravity at one half the width. Also, if the lashing is connected as shown in the sketch, instead of measuring c , the length of the lever from the tipping axis to the lashing CS, it is conservative to assume that it is equal to the width of the cargo item.

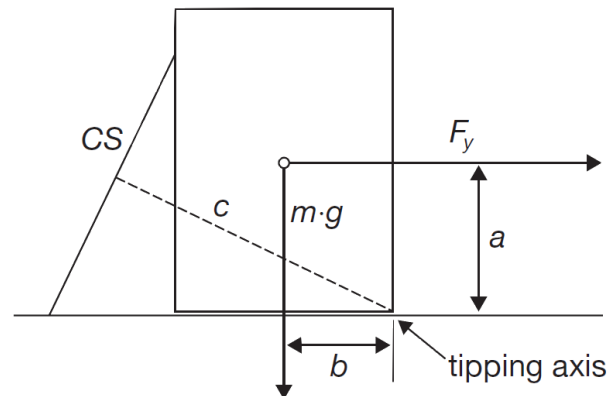

$$F_y \cdot a \leq b \cdot m \cdot g + 0.9 \cdot (CS_1 \cdot c_1 + CS_2 \cdot c_2 + CS_3 \cdot c_3 + CS_4 \cdot c_4)$$

$$312 \times 2.4/2 < 1.8/2 \times 68 \times 9.81 + 0.9 \times 1.8 \times (80 + 67 + 67 + 80)$$

$$374 < 600 + 476$$

$$374 < 1076 \text{ this is OK!}$$

APPENDIX 2

EXPLANATIONS AND INTERPRETATION OF METHODS TO ASSESS THE EFFICIENCY OF SECURING ARRANGEMENTS

1 The acceleration figures given in table 2, in combination with the correction factors, represent peak values on a 25-day voyage. This does not imply that peak values in x, y and z directions occur simultaneously with the same probability. It can be generally assumed that peak values in the transverse direction will appear in combination with less than 60% of the peak values in longitudinal and vertical directions.

2 Peak values in longitudinal and vertical directions may be associated more closely because they have the common source of pitching and heaving.

3 The advanced calculation method uses the "worst case approach". That is expressed clearly by the transverse acceleration figures, which increase to forward and aft in the ship and thereby show the influence of transverse components of simultaneous vertical accelerations. Consequently, there is no need to consider vertical accelerations separately in the balances of transverse forces and moments. These simultaneously acting vertical accelerations create an apparent increase of weight of the item and thus increase the effect of the friction in the balance of forces and the moment of stableness in the balance of moments. For this reason there is no reduction of the force $m \cdot g$ normal to the deck due to the presence of an angle of heel.

4 The situation is different for the longitudinal sliding balance. The worst case would be a peak value of the longitudinal force F_x accompanied by an extreme reduction of weight through the vertical force F_z .

5 The friction coefficients shown in the tables of this annex are generally lower than the ones given in other publications, such as the CTU Code. The reason for this can be seen in various influences which may appear in practical shipping, such as: vibration of the ship, moisture, grease, oil, dust and other residues.

6 There are certain stowage materials available which are said to increase friction considerably. Extended experience with these materials may bring additional coefficients into practical use.

7 The principal way of calculating forces within the securing elements of a complex securing arrangement should necessarily include the consideration of:

- .1 load-elongation behaviour (elasticity);
- .2 geometrical arrangement (angles, length); and
- .3 pre-tension, of each individual securing element.

8 This approach would require a large volume of information and a complex, iterative calculation. The results would still be doubtful due to uncertain parameters.

9 Therefore, the simplified approach was chosen with the assumption that the elements take an even load of CS (calculated strength) which is reduced against the MSL (maximum securing load) by the safety factor.

10 When employing the advanced calculation method, the way of collecting data should be followed as shown in the calculated example. It is acceptable to estimate securing angles, to take average angles for a set of lashings and similarly to arrive at reasonable figures of the levers a , b and c for the balance of moments.

11 It should be borne in mind that this annex contains a number of assumptions based on approximations. Even though safety factors are also incorporated, there is no clear-cut borderline between safety and non-safety. If in doubt, the arrangement should be improved.

APPENDIX 3

ADVANCED PROVISIONS AND CONSIDERATIONS APPLICABLE TO VERY HEAVY AND/OR VERY LARGE CARGO ITEMS

This appendix contains additional advice that may be considered for the stowage and securing of cargo with unusual characteristics, as referenced in chapter 1.8 of this Code and may include items of exceptional mass and/or dimension. However, the listed considerations do not claim to be complete.

1 Longitudinal tipping

For the securing of large and tall cargo items in longitudinal direction, the balance calculation should also consider longitudinal tipping and meet the following condition:

$$F_x \cdot a \leq b \cdot (m \cdot g - f_z \cdot F_z) + CS_1 \cdot c_1 + CS_2 \cdot c_2 + \dots + CS_n \cdot c_n \text{ [kNm]}$$

Where:

F_x , m , g , F_z , CS , n are as explained under 7.2.1 of this annex.

- a is lever-arm of tipping (m) (see figure 18)
- b is lever-arm of stability (m) (see figure 18)
- c is lever-arm of securing force (m) (see figure 18)

The factor f_z is obtained by the applicable relation of b/a as shown below:

b/a	0.1	0.2	0.3	0.4	0.6	1.0	2.0	3.0
f_z	0.50	0.70	0.80	0.85	0.90	0.94	0.98	1.00

2 Rotational inertia of large cargo items

2.1 The algorithm used in 7.2.2 of this annex and section 1 above for defining the tipping moment acting on a distinct cargo item replaces the physical extent of the item by its centre of gravity. The tipping moment is then declared as the determined horizontal force F_x or F_y , multiplied by the vertical distance "a" of this centre of gravity to the edge of the footprint, i.e. the tipping axis of the item. This is sufficiently accurate, as long as the spatial dimensions of the item remain below about 6 metres.

2.2 Larger items, however, will develop a substantial additional tipping moment by their rotational inertia against the rotational acceleration of the ship in rolling or pitching motions. The additional tipping moment is independent from the stowage position of the item in the ship and always positive, i.e. intensifying the tipping impulse. This phenomenon requires additional securing measures and, therefore, should be included in tipping balances for large cargo items by the use of a simple algorithm.

2.3 Transverse tipping balance

2.3.1 For cargo items of width w (measured athwartships) and height h , where $(w^2 + h^2) > 50 \text{ m}^2$, the additional tipping moment $k \cdot J$ due to rotational inertia of the cargo item should be added to the ordinary tipping moment $F_y \cdot a$ in the transverse tipping balance.

2.3.2 The appropriate figure of the moment of rotational inertia J should be supplied by the shipper related to the centre of gravity of the item for the plane of transverse tipping. If such information is not available, an estimated figure may be used by:

$$J = m \cdot \left(\frac{w^2+h^2}{12} \right) [tm^2] \text{ for homogeneous distribution of mass in the item}$$

$$J = m \cdot \left(\frac{(w+h)^2}{12} \right) [tm^2] \text{ for an item with peripheral concentration of mass.}$$

The reverse angular acceleration k may be taken as $k = \frac{36 \cdot GM}{B^2} [s^{-2}]$.

2.4 Longitudinal tipping balance

2.4.1 For cargo items of length l (measured fore and aft) and height h , where $(l^2 + h^2) > 50 m^2$, the additional tipping moment $k \cdot J$ due to rotational inertia of the cargo item should be added to the ordinary tipping moment $F_x \cdot a$ in the longitudinal tipping balance.

2.4.2 The appropriate figure of the moment of rotational inertia J should be supplied by the shipper related to the centre of gravity of the item for the plane of longitudinal tipping. If such information is not available, an estimated figure may be used by:

$$J = m \cdot \left(\frac{l^2+h^2}{12} \right) [tm^2] \text{ for homogeneous distribution of mass in the item}$$

$$J = m \cdot \left(\frac{(l+h)^2}{12} \right) [tm^2] \text{ for an item with peripheral concentration of mass}$$

The reverse angular acceleration k may be taken as $k = \frac{25}{L} [s^{-2}]$.

3 Separate consideration of wind and sea sloshing

3.1 The algorithm used in this annex for defining the horizontal force F_x or F_y , acting on a cargo item stowed on deck, combines horizontal weight components, inertia forces and wind/sloshing forces for reasons of simplification. This is correct for the balance of sliding; however, it is an approximation only for the balance of tipping. Particularly, high deck cargo items with their major wind exposed area well above the centre of gravity should be given a separate compilation of moments from wind forces, sea sloshing forces and gravity/inertia forces in order to get a more realistic tipping moment. The inertia forces strike on the centre of gravity of the cargo item, the sea sloshing strikes on the cargo area not more than 2 m above the weather deck and the wind forces strike on the lateral area of the cargo item exposed to wind.

Example: The figures of the tipping lever "a" relate to a large portal harbour crane shipped on deck of a heavy lift ship. The centres of attack by wind and spray deviate considerably from the centre of gravity. A separate compilation of the longitudinal tipping moment reads:

	F_x	a	$F_x \cdot a$
Gravity/inertia	1373 kN	13.0 m	17849 kNm
Wind	170 kN	20.0 m	3400 kNm
Spray	4 kN	1.0 m	4 kNm
Total	1547 kN		21253 kNm

3.2 The conventionally computed tipping moment would be only:

Total	1547 kN	13.0 m	20111 kNm
--------------	----------------	---------------	------------------

3.3 The surplus over the conventional tipping moment here is about 6%. The potential additional tipping moment by rotational inertia has not been reflected in this example.

4 Interpretation of "on deck high"

4.1 The stowage level "on deck high" in table 2 of annex 13 has been positioned at a distance above the water line of about two thirds of the ship's breadth. With extremely large cargo items this level can easily be exceeded. In order to avoid uncertainties in the determination of transverse and longitudinal accelerations in such cases, it is recommended to use the original mathematical model, which has been the basis for acceleration tables in annex 13. This model may easily be programmed, e.g. in a suitable spreadsheet.

4.2 The shown mathematical model is identical to that used in the *International Code for the Construction and Equipment of Ships Carrying Liquefied Gases in Bulk* (IGC Code) (resolution MSC. 5(48)). However, while in the IGC Code the probability level of accelerations refers to the lifetime of a ship of 10^4 days, annex 13, in order to remain within the scope of practical cargo securing experience, applies a reduction factor of 0.74, corresponding to the 25-day significant wave height in the North Atlantic. Furthermore, the model has been expanded to supply reasonable K -parameters for B/GM -relations less than 7, applicable to ships with exceptional large GM -values.

Mathematical model of the acceleration tables 2 to 4

4.3 The longitudinal, transverse and vertical accelerations acting on a cargo item may be obtained alternatively by the set of formulas as follows:

$$\begin{aligned} a_x &= c_1 \cdot c_2 \cdot c_3 \cdot a_{x0} \cdot g \text{ [m/s}^2\text{]} \\ a_y &= c_1 \cdot c_2 \cdot c_3 \cdot a_{y0} \cdot g \text{ [m/s}^2\text{]} \\ a_z &= c_1 \cdot c_2 \cdot c_3 \cdot a_{z0} \cdot g \text{ [m/s}^2\text{]} \end{aligned}$$

a_x : longitudinal acceleration (gravity component of pitch included)

a_y : transverse acceleration (gravity component of roll included)

a_z : vertical acceleration (component due to static weight not included)

c_1 : correction factor for navigation area, taken as 1.0 worldwide in annex 13

c_2 : correction factor for season, taken as 1.0 for whole year in the annex 13

c_3 : correction factor for 25 navigation days, taken as $0.6 + 0.1 \cdot \log_{10} 25 = 0.74$ in annex 13

$$a_{x0} = \pm a_0 \cdot \sqrt{0.06 + A^2 - 0.25 \cdot A}$$

$$a_{y0} = \pm a_0 \cdot \sqrt{0.6 + 2.5 \cdot \left(\frac{x}{L} + 0.05\right)^2 + K \cdot \left(1 + 0.6 \cdot K \cdot \frac{z}{B}\right)^2}$$

$$a_{z0} = \pm a_0 \cdot \sqrt{1 + \left(5.3 - \frac{45}{L}\right)^2 \cdot \left(\frac{x}{L} + 0.05\right)^2 \cdot \left(\frac{0.6}{C_b}\right)^{3/2}}$$

therein:

$$a_0 = 0.2 \cdot \frac{v}{\sqrt{L}} + \frac{34 - 600/L}{L}$$

$$A = \left(0.7 - \frac{L}{1200} + \frac{5 \cdot z}{L} \right) \cdot \left(\frac{0.6}{C_b} \right)$$

$$K = R \cdot \frac{13 \cdot GM}{B}, \text{ but never less than } 1.0$$

$$R = \left(\frac{B}{7 \cdot GM} \right)^{\left(\frac{GM}{B} \right)}, \text{ but never greater than } 1.0$$

L = length between perpendiculars [m]

B = moulded breadth of ship [m]

GM = metacentric height of ship [m]

C_b = block coefficient of ship

x = longitudinal distance from amidships to calculating point, positive forward [m]

z = vertical distance from actual waterline to calculating point, positive upward [m]

v = service speed [knots]

g = gravity acceleration = 9.81 [m/s²]

5 Structural strength assessment

5.1 Dry cargo ships are typically designed on the assumption that cargo is homogeneously distributed. The maximum permissible surface load is usually specified in the ship's documentation and given in t/m² for all relevant stowage areas, i.e. double bottom (tank top), top of stepped side tanks, 'tween deck pontoons, weather deck and weather deck hatch covers.

5.2 Heavy cargo items tend to produce concentrated strip or point loads rather than homogeneous loads. Then care should be taken that the stress parameters, corresponding to the maximum permissible homogeneous load, are not exceeded by the load induced by the heavy item. The essential parameters for stresses in deck sections, hatch covers and 'tween deck pontoons or panels are shear forces and bending moments. Suitable steel or timber beams or equivalent panel structures should be used to transfer the strip or point load to the primary members of the load-bearing structure.

5.3 Where a loading situation appears to be too complex to be safely examined by manual calculation or where stress parameters obtained by a manual calculation method come close to the applicable limit of the supporting structure, utilization of finite element analysis should be considered.

6 Weather routing

6.1 Utilizing weather routing services may significantly contribute to performing a safe passage. Care should be taken that the engaged service complies with the recommendations laid down in MSC/Circ.1063 on *Participation of ships in weather routing services*.

6.2 In case of transporting heavy and/or large cargo items, where safe securing is an essential requirement, the routing decisions should be oriented to the avoidance of severe ship motions rather than to other criteria, such as swift passage or fuel economy. However, the engagement of a weather routing service does not eliminate the need for the application of securing measures as required in this annex.

7 Other considerations

When planning the transport of very heavy and/or very large cargo items on deck of a vessel, particular consideration should be given to:

- .1 the observation of sight line requirements as stipulated in SOLAS regulation V/22, and, in case of non-compliance, the conditions for a temporary exemption by the Flag State Administration;
- .2 the provision of unimpeded radar transmission with due observation of resolution MSC.192(79) on *Revised performance standards for radar equipment* and SN.1/Circ.271 on *Guidelines for the installation of shipborne radar equipment*; and
- .3 the provision of visibility of navigations light as required by annex I of International Regulations for Preventing Collisions at Sea and specified in resolution MSC.253(83) on *Performance standards for navigation lights, navigation light controllers and associated equipment*.

APPENDIX 4

ADVANCED PROVISIONS AND CONSIDERATIONS APPLICABLE TO SEMI-STANDARDIZED CARGOES

This appendix contains advice that may be considered for the stowage and securing of semi-standardized cargoes in addition to the other provisions of chapter 4, annex 4 and annex 13 of this Code.

The provisions in section 1 below may be used for the following conditions:

- .1 worst case accelerations are used for the design of securing arrangements of semi-standardized cargoes, i.e. the most severe external forces within the particular deck or otherwise defined region of the vessel are applied;
- .2 uniform securing arrangements are used for types of cargo items considering stepped weight classes, whereby arrangements always cover the highest weight within a class and the most unfavourable position of the centre of gravity;
- .3 the range of lashing angles is well defined by the pattern of securing points in the vessel, as well as on vehicles. The assessment uses worst case angles, i.e. the worst combination of vertical and horizontal angles within the given ranges; and
- .4 securing equipment is regularly inspected when used for recurrent application.

1 Performance factor for short voyages

For cargo securing arrangements considered in section 7.1 case .3 (short duration voyages up to 72 hours), the forces and moments on the right side of the balance equations in section 7.3 may be multiplied by the F_P performance factor of 1.15, as illustrated below:

$$\text{Transverse sliding: } F_y \leq (\mu \cdot m \cdot g + f_{y1} \cdot CS_1 + \dots + f_{yn} \cdot CS_n) \cdot F_P$$

$$\text{Longitudinal sliding: } F_x \leq (\mu \cdot (m \cdot g - f_z \cdot F_z) + f_{x1} \cdot CS_1 + \dots + f_{xn} \cdot CS_n) \cdot F_P$$

$$\text{Transverse tipping: } F_y \cdot a \leq (b \cdot m \cdot g + 0.9 \cdot (CS_1 \cdot c_1 + CS_2 \cdot c_2 + \dots + CS_n \cdot c_n)) \cdot F_P$$

2 Asymmetrical securing arrangements

For asymmetrical lashing arrangements and for cargoes resting on supports with different coefficients of friction, separate sliding of the item's fore and aft ends should be considered in the transverse direction. The calculations for each end should be based on the part of the item's weight resting on each support and the characteristics of the cargo securing devices attached to each end.

3 Safety factor

In the case of elementary securing arrangements, where no more than two devices per impact direction are used and loads are evenly distributed by proper orientation to the centre of gravity of the cargo item, the calculated CS of securing devices may be obtained by:

$$CS = \frac{MSL}{1.2}$$

The specific conditions for the use of the reduced safety factor should be outlined in the ship's Cargo Securing Manual.

4 Friction coefficients

In addition to the friction coefficients in table 5 in section 7.2, the following friction coefficients (μ) may be applied.

Table 8 – Additional friction coefficients

Materials in contact	Friction coefficient (μ)
Steel–rubber tyre, dirty, wet or dry	0.3
Steel–solid rubber tyre, dry and clean ⁵	0.3
Steel–air rubber tyre, wet and clean ⁵	0.4
Steel–air rubber tyre, dry and clean ⁵	0.45

5 Effect of parking brake and wheel chocks

For wheel-based cargoes, the effect of parking brakes as well as the effect of wheel chocks may be taken into account when dimensioning securing arrangements against movement in the rolling direction. Usually parking brakes have a braking capacity corresponding to a force equal to $0.2 \cdot g \cdot GVM$ (kN), where GVM is the gross vehicle mass of the item in tonnes and in most cases the parking brake is applied on one axle only. If a wheel is chocked it can be considered not to roll and the friction in the rolling direction should be taken as the lesser of the friction between the tyre and the ship's deck, and the chock and the ship's deck."

⁵ Conditions of cleanliness as defined in the ship's Cargo Securing Manual.