

# **Skibs- og marinteknologi – Lodsstiger – Del 1: Design og specifikation**

Ships and marine technology – Pilot ladders –  
Part 1: Design and specification

**DANSK STANDARD**  
Danish Standards Association

Göteborg Plads 1  
DK-2150 Nordhavn

Tel: +45 39 96 61 01

Tel: +45 39 96 61 01

[dansk.standard@ds.dk](mailto:dansk.standard@ds.dk)

[www.ds.dk](http://www.ds.dk)

© Dansk Standard - Eftertryk uden tilladelse forbudt

# DS/ISO 799-1:2019

København

DS projekt: M318259

ICS: 47.020.50

**Første del af denne publikations betegnelse er:**

**DS/ISO, hvilket betyder, at det er en international standard, der har status som dansk standard.**

**Denne publikations overensstemmelse er:**

**IDT med: ISO 799-1:2019**

**DS-publikationen er på engelsk.**

---

## **DS-publikationstyper**

Dansk Standard udgiver forskellige publikationstyper.

Typen på denne publikation fremgår af forsiden.

Der kan være tale om:

### **Dansk standard**

- standard, der er udarbejdet på nationalt niveau, eller som er baseret på et andet lands nationale standard, eller
- standard, der er udarbejdet på internationalt og/eller europæisk niveau, og som har fået status som dansk standard

### **DS-information**

- publikation, der er udarbejdet på nationalt niveau, og som ikke har opnået status som standard, eller
- publikation, der er udarbejdet på internationalt og/eller europæisk niveau, og som ikke har fået status som standard, fx en teknisk rapport, eller
- europæisk præstandard

### **DS-håndbog**

- samling af standarder, eventuelt suppleret med informativt materiale

### **DS-hæfte**

- publikation med informativt materiale

Til disse publikationstyper kan endvidere udgives

- tillæg og rettelsesblade

## **DS-publikationsform**

Publikationstyperne udgives i forskellig form som henholdsvis

- fuldtekstpublikation (publikationen er trykt i sin helhed)
- godkendelsesblad (publikationen leveres i kopi med et trykt DS-omslag)
- elektronisk (publikationen leveres på et elektronisk medie)

## **DS-betegnelse**

Alle DS-publikationers betegnelse begynder med DS efterfulgt af et eller flere præfikser og et nr., fx **DS 383**, **DS/EN 5414** osv. Hvis der efter nr. er angivet et **A** eller **Cor**, betyder det, enten at det er et **tillæg** eller et **rettelsesblad** til hovedstandard, eller at det er indført i hovedstandard.

DS-betegnelse angives på forsiden.

## **Overensstemmelse med anden publikation:**

Overensstemmelse kan enten være IDT, EQV, NEQ eller MOD

- **IDT:** Når publikationen er identisk med en given publikation.
- **EQV:** Når publikationen teknisk er i overensstemmelse med en given publikation, men præsentationen er ændret.
- **NEQ:** Når publikationen teknisk eller præsentationsmæssigt ikke er i overensstemmelse med en given standard, men udarbejdet på baggrund af denne.
- **MOD:** Når publikationen er modificeret i forhold til en given publikation.

# INTERNATIONAL STANDARD

# ISO 799-1

First edition  
2019-02-26

---

---

## **Ships and marine technology — Pilot ladders —**

### **Part 1: Design and specification**

*Navires et technologie maritime — Échelles de pilote —  
Partie : Conception et spécification*



Reference number  
ISO 799-1:2019(E)



## **COPYRIGHT PROTECTED DOCUMENT**

© ISO 2019, Published in Switzerland

All rights reserved. Unless otherwise specified, no part of this publication may be reproduced or utilized otherwise in any form or by any means, electronic or mechanical, including photocopying, or posting on the internet or an intranet, without prior written permission. Permission can be requested from either ISO at the address below or ISO's member body in the country of the requester.

ISO copyright office  
Ch. de Blandonnet 8 • CP 401  
CH-1214 Vernier, Geneva, Switzerland  
Tel. +41 22 749 01 11  
Fax +41 22 749 09 47  
copyright@iso.org  
www.iso.org

# Contents

Page

|   |           |
|---|-----------|
| <b>Foreword</b> .....   | <b>iv</b> |
| <b>Introduction</b> .....   | <b>v</b>  |
| <b>1 Scope</b> .....  | <b>1</b>  |
| <b>2 Normative references</b> .....                               | <b>1</b>  |
| <b>3 Terms and definitions</b> .....                              | <b>1</b>  |
| <b>4 Materials</b> .....  | <b>1</b>  |
| 4.1 Wooden parts.....   | 1         |
| 4.2 Side ropes.....   | 1         |
| 4.2.1 General arrangement.....                                    | 1         |
| 4.2.2 Alternative side rope arrangement.....                      | 2         |
| 4.3 Metallic materials.....                                       | 2         |
| 4.4 Step fixtures.....  | 2         |
| 4.5 Plastic materials.....  | 2         |
| 4.6 Quality of materials.....                                     | 2         |
| 4.7 Rope seizing.....   | 2         |
| <b>5 Construction</b> .....                                       | <b>3</b>  |
| <b>6 Testing and inspection</b> .....                             | <b>9</b>  |
| 6.1 Prototype test for approval.....                              | 9         |
| 6.2 Product inspection.....                                       | 11        |
| <b>7 Designation</b> .....  | <b>11</b> |
| <b>8 Marking</b> .....  | <b>11</b> |
| <b>9 Production tests and examinations</b> .....                  | <b>12</b> |
| <b>10 Maintenance</b> .....                                       | <b>12</b> |
| <b>Annex A (normative) Production tests and inspections</b> ..... | <b>13</b> |

## Foreword

ISO (the International Organization for Standardization) is a worldwide federation of national standards bodies (ISO member bodies). The work of preparing International Standards is normally carried out through ISO technical committees. Each member body interested in a subject for which a technical committee has been established has the right to be represented on that committee. International organizations, governmental and non-governmental, in liaison with ISO, also take part in the work. ISO collaborates closely with the International Electrotechnical Commission (IEC) on all matters of electrotechnical standardization.

The procedures used to develop this document and those intended for its further maintenance are described in the ISO/IEC Directives, Part 1. In particular, the different approval criteria needed for the different types of ISO documents should be noted. This document was drafted in accordance with the editorial rules of the ISO/IEC Directives, Part 2 (see [www.iso.org/directives](http://www.iso.org/directives)).

Attention is drawn to the possibility that some of the elements of this document may be the subject of patent rights. ISO shall not be held responsible for identifying any or all such patent rights. Details of any patent rights identified during the development of the document will be in the Introduction and/or on the ISO list of patent declarations received (see [www.iso.org/patents](http://www.iso.org/patents)).

Any trade name used in this document is information given for the convenience of users and does not constitute an endorsement.

For an explanation of the voluntary nature of standards, the meaning of ISO specific terms and expressions related to conformity assessment, as well as information about ISO's adherence to the World Trade Organization (WTO) principles in the Technical Barriers to Trade (TBT) see [www.iso.org/iso/foreword.html](http://www.iso.org/iso/foreword.html).

This document was prepared by Technical Committee ISO/TC 8, *Ships and marine technology*, Subcommittee SC 1, *Lifesaving and fire protection*.

This first edition of [ISO 799-1](#) cancels and replaces [ISO 799:2004](#), which has been technically revised. This first edition takes into account new designs and manufacturing methods for pilot ladders, which have entered the market since 2004.

A list of all parts in the ISO 799 series can be found on the ISO website.

Any feedback or questions on this document should be directed to the user's national standards body. A complete listing of these bodies can be found at [www.iso.org/members.html](http://www.iso.org/members.html).

## Introduction

This document is intended to supplement existing IMO requirements for pilot ladders. Since IMO instruments do not include specific requirements for prototype testing of pilot ladders for approval, the tests included in this document are in excess of the existing IMO requirements. The reservation and inclusion of these tests was considered necessary in order to provide a means of ensuring conformance of pilot ladders with the performance requirements prescribed in IMO instruments and in this document.

This document can be used for independent acceptance of a pilot ladder complying with SOLAS, in which case certification must be issued from a signatory state of SOLAS.

NOTE — ISO 799 is incorporated by reference and footnoted in the International Convention on Safety of Life at Sea (SOLAS) Chapter V Regulation 23.2.3.

1



# Ships and marine technology — Pilot ladders —

## Part 1: Design and specification

### 1 Scope

This document specifies requirements for pilot ladders of a ship, which are provided to enable a maritime pilot to embark and disembark from a ship safely against a vertical portion of the ship's hull. It is applicable to merchant ships which embark and disembark maritime pilots with the ship underway.

### 2 Normative references

The following documents are referred to in the text in such a way that some or all of their content constitutes requirements of this document. For dated references, only the edition cited applies. For undated references, the latest edition of the referenced document (including any amendments) applies.

[ISO 209:2007](#), *Aluminium and aluminium alloys — Chemical composition*

[ISO 877-2:2009](#), *Plastics — Methods of exposure to solar radiation — Part 2: Direct weathering and exposure behind window glass*

[ISO 1181:2004](#), *Fibre ropes — Manila and sisal — 3-, 4- and 8-strand ropes*

[ISO 1461](#), *Hot dip galvanized coatings on fabricated iron and steel articles — Specifications and test methods*

[ISO 15510:2014](#), *Stainless steels — Chemical composition*

### 3 Terms and definitions

No terms and definitions are listed in this document.

ISO and IEC maintain terminological databases for use in standardization at the following addresses:

- ISO Online browsing platform: available at <https://www.iso.org/obp>
- IEC Electropedia: available at <http://www.electropedia.org/>

### 4 Materials

#### 4.1 Wooden parts

Each wooden part shall be made of hardwood (ash, oak, beech, teak, and other hardwood having equivalent properties) free from knots. Wood shall not be treated or coated with paint, varnish or other coatings, which either change the friction coefficient or hide the natural grain.

#### 4.2 Side ropes

##### 4.2.1 General arrangement

Each side rope shall be mildew-resistant manila rope meeting [ISO 1181:2004](#), Quality 1, or a spun thermoset polyester rope with a polypropylene core of a colour that contrasts with the spun polyester.

Each side rope shall have a breaking strength of at least 24 kN, and the specification of the diameter of side ropes should be 20 mm (63 mm circumference).

#### **4.2.2 Alternative side rope arrangement**

Alternative side ropes of synthetic material may be used if they:

- a) meet the breaking strength and size requirements of [4.2.1](#);
- b) are at least as resistant to elongation under load as the standard ropes described in [4.2.1](#);
- c) have an exterior surface suitable to be grasped by bare hands, similar to manila or spun polyester;
- d) are of a thermoset polymer, resistant to deterioration from ultraviolet light; and
- e) provide a visual indication of excessive wear, similar to the spun polyester/polypropylene construction described in [4.2.1](#).

#### **4.3 Metallic materials**

**4.3.1** Each metal fastener shall be made of material which is inherently corrosion-resistant, or treated to be corrosion-resistant.

**4.3.2** Each ferrous metal part, which is not stainless steel, shall be coated in accordance with [ISO 1461](#).

**4.3.3** Each stainless steel part shall be of a marine grade alloy with a corrosion resistance at least equal to grade "4401-316-00I" in [ISO 15510:2014](#).

**4.3.4** Each aluminium part shall be 5 254 alloy, or other grade containing not more than 0,06 % copper, in accordance with [ISO 209:2007](#).

**4.3.5** Metals in contact with each other shall be galvanically compatible, or insulated to prevent galvanic corrosion in a marine environment.

#### **4.4 Step fixtures**

Step fixtures for securing each step of a ladder shall have rope seizing or purpose made arrangement such as solid nylon clamp blocks or hardwood clamp blocks to prevent the fasteners from loosening. Cable ties, u-clamps, worm driven clips are unacceptable.

#### **4.5 Plastic materials**

Each plastic material shall be of a type that retains at least 30 % of its original tensile strength and at least 80 % of its original impact strength when subjected to the one-year outdoor weathering test described in Method A of [ISO 877-2:2009](#).

#### **4.6 Quality of materials**

Each part of a ladder shall be free of splinters, burrs, sharp edges, corners, projections, or other defects that could injure a person using the ladder.

#### **4.7 Rope seizing**

Seizing, shall consist of three-ply tarred marline of minimum breaking strength 800 N, and with a minimum diameter of 4 mm, or other suitable material of equivalent strength and diameter. All seizings shall be figure-of-eight racking seizings, minimum length of seizing 32 mm.

## 5 Construction

5.1 [Figure 1A](#) provides construction details for pilot ladders.

Dimensions in millimetres

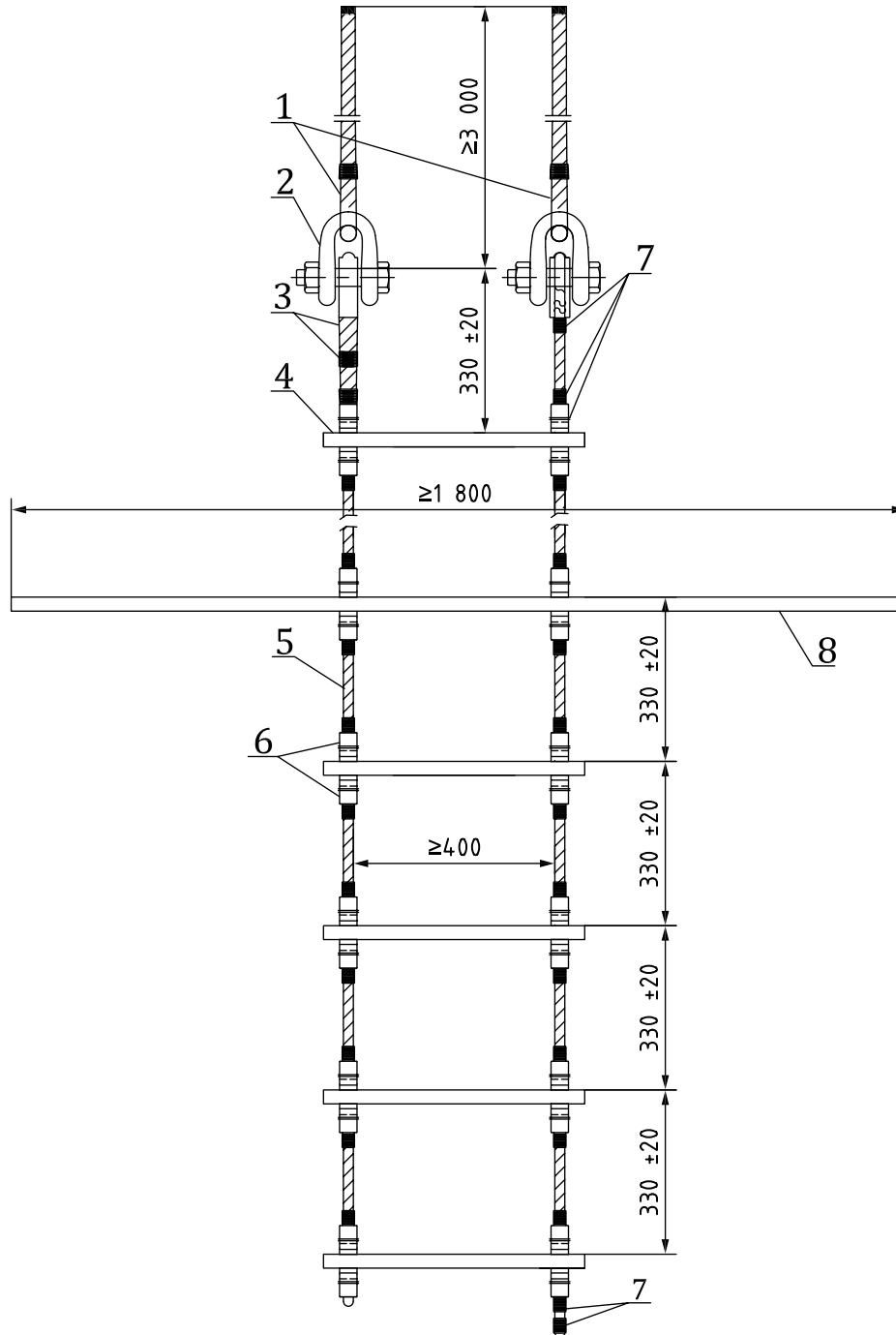

### Key

- |   |  |   |               |
|---|--|---|---------------|
| 1 | securing rope alternative arrangements | 5 | side rope     |
| 2 | shackle                                | 6 | step fixture  |
| 3 | splice and rope seizing                | 7 | rope seizing  |
| 4 | step                                   | 8 | spreader step |

**Figure 1A — Construction details of pilot ladder**

**5.2** Each step in the ladder shall be supported by side ropes. Each side of the ladder shall consist of a continuous loop of rope with the joint above the top step or below the bottom step.

**5.3** Each of the side ropes shall:

- a) be wholly continuous rope without any knots, joints or splices except as specified in [5.4](#).
- b) not be painted or otherwise coated or covered.

**5.4** Unless a special arrangement is needed to secure the ladder to an accommodation ladder, pilot ladder winch reel, or other custom installation, the ends of the side ropes shall be finished as follows.

- a) If the ends of the side ropes terminate just above the top step (highest step), they shall round a thimble and the end shall be joined with a short splice.
- b) The side ropes shall not have fittings or form loops at the bottom of the ladder that can be used to attach additional ladder sections or tripping lines.
- c) If the ends of the side ropes on each side terminate just beneath the lowest step, the rope ends shall be securely fastened or otherwise treated to prevent fraying. The rope ends shall pass through the holes in the lowest step and use similar step fixtures as the other steps. A rope seizing, as per the other steps, shall be made immediately under step fixtures. A second rope seizing shall be provided 60 mm under the first seizing, see [Figure 1B](#). The loose ends of the rope shall be whipped as close as possible to the second rope seizing to protect against fraying. An accepted method is a 25 mm whipping. The loose ends of the rope shall be as short as possible, but not less than 50 mm below the second seizing and under no circumstances can loops be allowed.
- d) The ends of each side rope, which do not terminate in a splice or fitting, shall be served, whipped or otherwise treated to prevent fraying.

Dimensions in millimetres

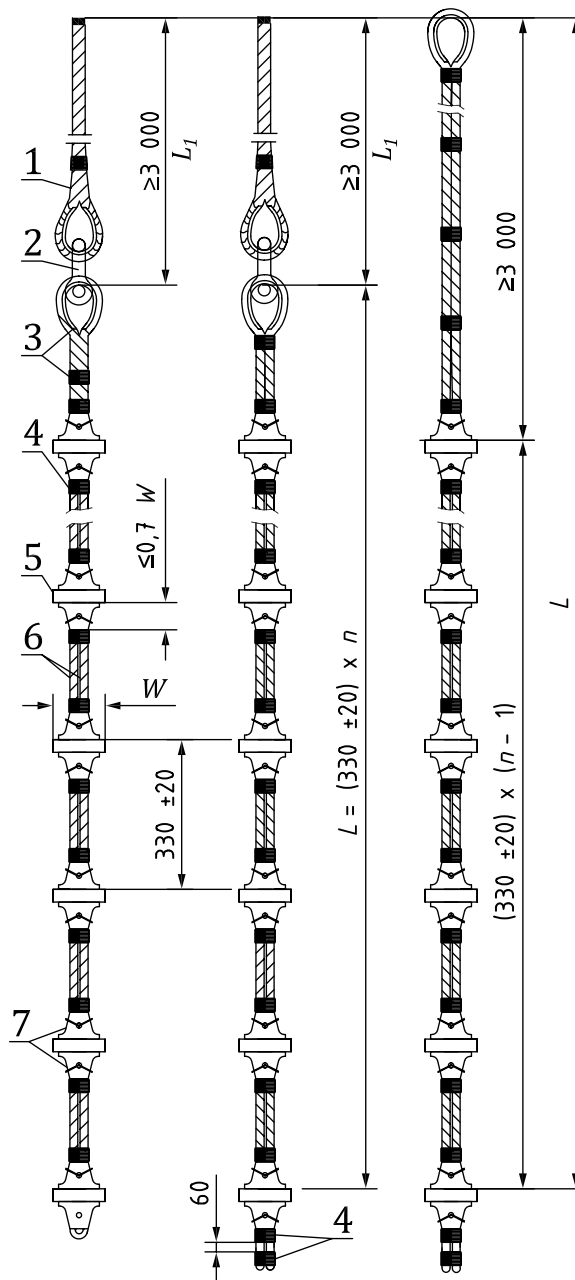

**Key**

- |   |  |       |                               |
|---|--|-------|-------------------------------|
| 1 | securing rope alternative arrangements | 7     | step fixture                  |
| 2 | shackle                                | $L_1$ | length of securing rope       |
| 3 | splice and rope seizing                | $L$   | length of ladder              |
| 4 | rope seizing                           | $W$   | width of the step             |
| 5 | step                                   | $n$   | number of steps in the ladder |
| 6 | side rope                              |       |                               |

**Figure 1B — Ladder construction using rope seizing and step fixtures and alternative securing rope arrangements at top of ladder**

5.5 Each side rope shall pass through a separate hole in each step. The centre of each hole shall be at least 50 mm from the short edge of the step as shown in [Figure 2](#). Alternative arrangements using slots

are shown in [Figure 2](#) and are permitted only for replacement steps and the slots shall be in the longer edge of the replacement step.

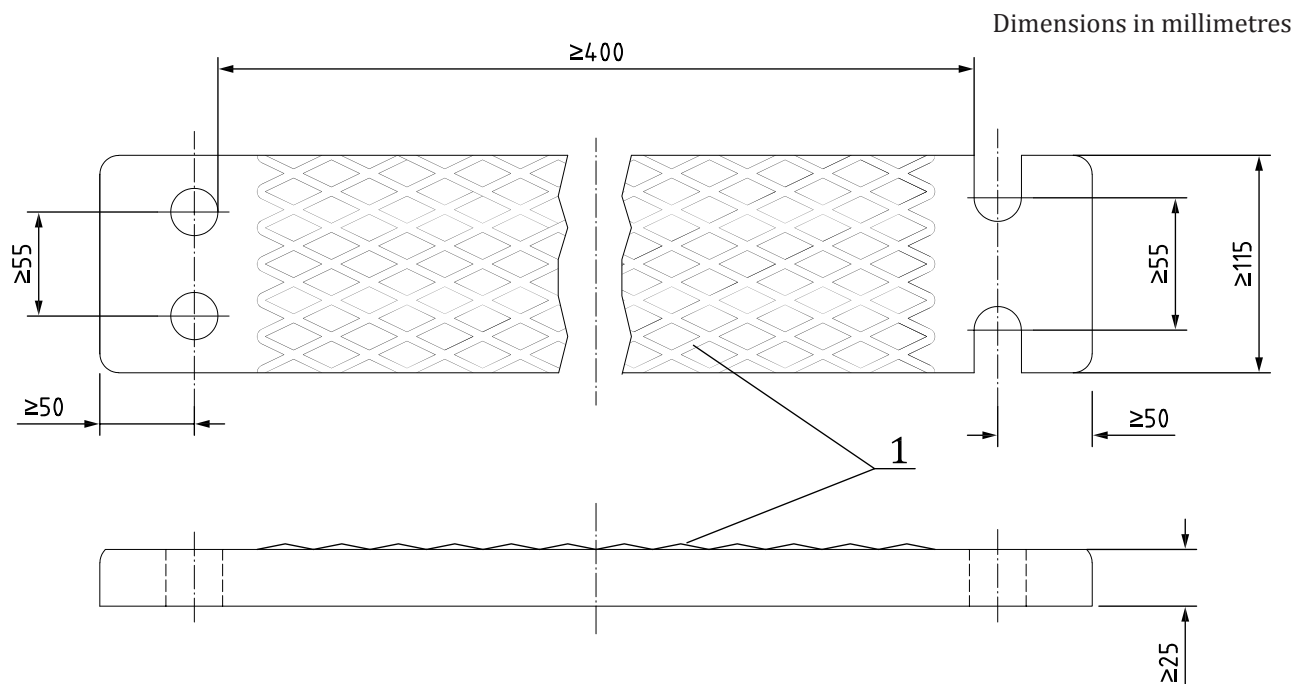

#### Key

- 1 grooved, patterned or textured non-skid surface area

**Figure 2 — Alternative hole and slot types for side ropes of typical ladder step and replacement step**

**5.6** Each pair of side ropes shall be secured together, both above and below each step, with specially designed step fixtures (chocks or widgets) which hold each step level when the ladder is hanging freely. Alternative acceptable arrangements are shown in [Figure 1B](#).

**5.7** If step fixtures are used to secure the side ropes and hold the step in place, the step fixtures shall not extend above or below the step surfaces by more than a distance equal to  $0,7 \times W$  (where  $W$  is the width of the step), so that the step is not prevented from rolling if caught between a boat and the hull of the ship.

**5.8** If a seizing method is used to secure steps and side ropes, step fixtures shall be used above and below the step. The step fixtures shall be designed to lead and support the side ropes from the step to the point above or below the step where the side ropes are seized together. The step fixtures shall be designed so that they stay in place when the ladder is rolled or the step is turned.

**5.9** The clear space between the side ropes on one side of the ladder and those on the other side shall be at least 400 mm, see [Figure 2](#) and [Figure 3](#). This distance shall be uniform throughout the length of the ladder, See [Figure 1A](#).

**5.10** Each side rope shall be arranged so that, when the ladder is in use against the vertical hull of a ship, the side rope cannot come in contact with the ship's side.

**5.11** A securing rope, if used to aid in rigging the ladder, shall be shackled at the upper end of each side rope of the ladder, as shown in [Figure 1A](#) and [Figure 1B](#). Both securing ropes shall be of equal length and

shall have a breaking strength of at least 48 kN. Securing ropes shall be fitted with a thimble. The other end shall be treated to prevent fraying. A suitable method to prevent fraying is a whipping.

**5.12** The length of each securing rope shall be at least 3 m. The securing rope shall not be directly cut or spliced to the side rope.

**5.13** The spacing from the top of one step to the top of the next step shall be  $330 \pm 20$  mm, and shall be uniform throughout the length of the ladder. If there is no securing rope at the upper end of the ladder as specified by purchaser, the splice eyelet or sling shall be at least 3 m above the upper end of the top step. See [Figure 1B](#).

**5.14** Each step shall be of one-piece construction, of either hardwood or resilient plastic or rubber material complying with the applicable requirements of [Clause 4](#).

**5.15** The top face of each step shall be in rectangular form with a width not less than 115 mm, and its surface is grooved or patterned, or of a textured non-skid type. The step surface shall be designed so that it does not retain water. A textured non-skid surface shall be integral with the step and shall be either moulded or cut into the step with the nominal depth of 3 mm. Non-skid adhesive sheeting may not be used. See [Figure 2](#).

**5.16** Each step shall be at least 25 mm thick at its thinnest point. In determining this thickness, the depth of grooves in the top face of the step, the diameter of any hole extending from one side of the step to the other, and the thickness of any non-skid treatment shall not be included. See [Figure 2](#).

**5.17** Each step shall be arranged so that it can bear on the vertical hull of the ship when the ladder is in use.

**5.18** The manufacturer shall offer replacement steps, including replacement spreader steps, for the ladder that can replace a removed step, without the need for unstringing and restringing the ladder. Replacement steps shall meet all of the requirements in this document for steps, and each step shall be supplied with all parts necessary to install the step in the ladder.

**5.19** Each pilot ladder shall be capable of being rolled up for storage. Each ladder shall be capable of unrolling freely and hanging vertically.

**5.20** The four lowest steps of the ladder shall be made only of resilient synthetic or rubber materials. The rest of the ladder steps shall be of either hardwood or synthetic material.

**5.21** For the convenience of manoeuvring the pilot ladder to the required height, the permanent marking is made every three steps (approximately every 1 m).

**5.22** Each pilot ladder with more than five steps shall have one or more spreader steps at the positions indicated in [Table 1](#).

**5.23** Each spreader step shall meet the requirements for other ladder steps, except that each spreader step shall be at least 1,8 m long. See [Figure 3](#).

**Table 1 — Number of steps and relative positions of spreaders**

| Number of steps | Position(s) of spreader step(s) |
|-----------------|---------------------------------|
| 6               | 5                               |
| 7               | 5                               |
| 8               | 5                               |
| 9               | 5                               |
| 10              | 5                               |
| 11              | 5                               |
| 12              | 5                               |
| 13              | 5                               |
| 14              | 5, 12                           |
| 15              | 5, 13                           |
| 16              | 5, 14                           |
| 17              | 5, 14                           |
| 18              | 5, 14                           |
| 19              | 5, 14                           |
| 20              | 5, 14                           |
| 21              | 5, 14                           |
| 22              | 5, 14                           |
| 23              | 5, 14, 21                       |
| 24              | 5, 14, 22                       |
| 25              | 5, 14, 23                       |
| 26              | 5, 14, 23                       |
| 27              | 5, 14, 23                       |
| 28              | 5, 14, 23                       |
| 29              | 5, 14, 23                       |
| 30              | 5, 14, 23                       |
| 31              | 5, 14, 23                       |
| 32              | 5, 14, 23, 30                   |
| 33              | 5, 14, 23, 31                   |
| 34              | 5, 14, 23, 32                   |
| 35              | 5, 14, 23, 32                   |
| 36              | 5, 14, 23, 32                   |

NOTE 1 Spreader-step positions are determined by the step number counted from the bottom of the ladder.

NOTE 2 Pilot ladders with special over dimension lengths can also be accepted upon the approval of relevant departments, such as the ship owner and designers.



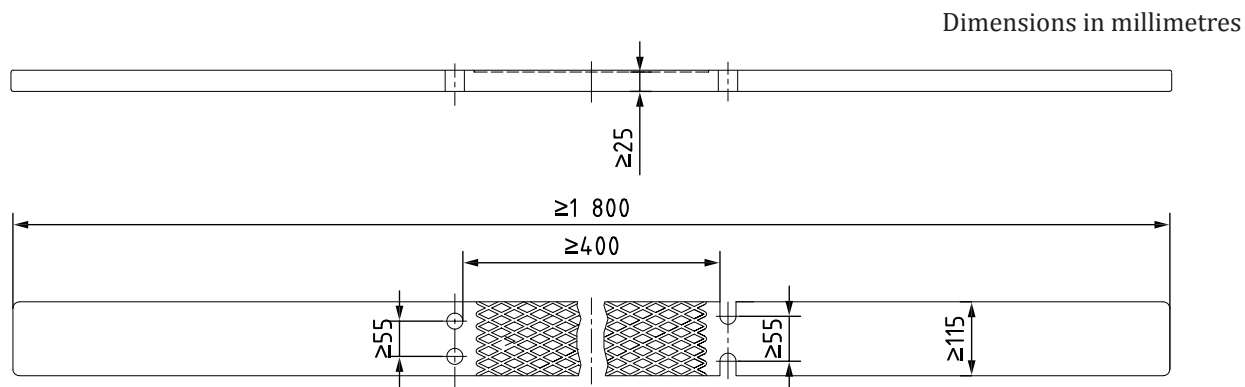

**Figure 3 — Pilot ladder spreader step and replacement spreader step construction, hole and slot types for side ropes**

## 6 Testing and inspection

### 6.1 Prototype test for approval

A prototype ladder and its components shall be subjected to the tests and meet the criteria specified in [Table 2](#). A fully assembled ladder shall be used in the tests. Any step or other part of the ladder which is permanently deformed as a result of testing shall not be used in a ladder which is placed in service. If the ladder fails one of the tests, the cause of the failure shall be identified and any needed design changes made. After a test failure and any design change, the failed test, and any other previously completed tests affected by the change, shall be redone.

**Table 2 — Prototype tests**

| Test               | Item to be tested  | Test procedure   | Acceptance criteria   |
|--------------------|--|--|---|
| Visual examination | Fully assembled ladder.  | Compare to construction requirements in <a href="#">Clause 5</a> , and the manufacturer's drawings.  | The ladder shall be in accordance with the construction requirements in <a href="#">Clause 5</a> , and be constructed in accordance with the manufacturer's drawings.                         |
| Step flexibility   | Six steps, which shall include at least one of each different type, from steps used in the ladder's original construction. | Place each step on a pair of supports located where the side ropes would normally pass through the step. Apply a static load uniformly for a period of at least 1 min over a 100 mm wide contact area at the centre of the step. The load shall be 3,0 kN, except that the load shall be 1,4 kN for a step limited to use as one of the four lowest steps in the ladder. | Deflection at the centre of the step shall not exceed 25 mm under load.<br><br>There shall be no residual deflection after the load is removed and the step has a maximum of 60 s to recover. |

Table 2 (continued)

| Test                                | Item to be tested   | Test procedure   | Acceptance criteria  |
|-------------------------------------|---|--|--|
| Step friction                       | <p>One step of each different material of construction and step surface design.</p> <p>One reference step constructed of clean oak, 115 mm wide and 480 mm long. The step surface should have grooves 3 mm wide, 3 mm deep, and 15 mm apart. The grooves shall run parallel to each other and parallel to the long edge of the step.</p> <p>One metal block of a mass between 1,5 kg and 3,0 kg. The metal block shall have a flat surface no more than 100 mm wide by 135 mm long. The flat surface shall have leather or composition shoe-sole material attached to it.</p> | <p>Set the reference step in a level position. Place the metal block at the centre of the stepping surface on the reference step, with the shoe-sole material resting on the stepping surface of the reference step, and with the longer edge of the metal block running across the reference step over both edges. Slowly raise one edge of the step with the metal block on it. Measure the angle at which the block begins to slide.</p> <p>Repeat the procedure with the standard reference step and the block under water.</p> <p>Repeat the procedure in both dry and wet conditions using each different ladder step.</p>   | <p>The angles at which the block begins to slide on the dry and wet pilot ladder step shall be greater than or equal to the corresponding angles measured for the standard reference step.</p>   |
| Step surface durability             | <p>One step of each different material of construction and step surface design.</p> <p>A metal block of the type described under the step friction test, arranged to enable a vertical load of 380 N to be applied to it as it slides back and forth over the step under test.</p>  | <p>Secure the step in a horizontal position, with the loaded block resting on it. Move the block back and forth from one end of the step surface to the other and back in the same line, for a total of 1 500 cycles.</p> <p>Repeat the step friction test on the worn step in both dry and wet conditions, making sure the sliding block is resting completely on the worn surface of the step.</p>   | <p>The angles at which the block begins to slide on the dry and wet pilot ladder step shall be greater than or equal to the corresponding angles measured for the standard reference step.</p>   |
| Ladder and step attachment strength | <p>Fully assembled ladder of longest length to be approved</p>  | <p>Suspend the ladder vertically hanging to its full length, or extend the ladder to its full length on a horizontal surface, with the top end of the ladder secured using its own attachments. Apply a static load of 8,8 kN widely distributed over the bottom step for a period of at least 1 min, so that the load is applied evenly between the side ropes through the step attachment fittings. Repeat the procedure at five different steps, except that the ladder is not required to be hanging at full length and only the step under test, its side rope attachments, and the side ropes immediately above the step attachment fittings are required to be subjected to the load.</p> | <p>Steps shall not break or crack.</p> <p>Attachments between any step and a side rope shall not loosen or break.</p> <p>Side ropes shall not sustain any observable damage, elongation, or deformation that remains after the test load is removed.</p> |

Table 2 (continued)

| Test      | Item to be tested                                       | Test procedure   | Acceptance criteria  |
|-----------|---|--|--|
| Unrolling | Fully assembled ladder of longest length to be approved | Attach the rolled-up ladder to anchoring fixtures in a place away from any wall or structure that would prevent it from falling freely, and where it can hang vertically. Allow the ladder to unroll freely. | The steps and attachments shall not be cracked, broken, or loose.<br>The ladder shall not sustain damage that would make it unsafe to use. |

## 6.2 Product inspection

Each production of pilot ladders shall be confirmed by visual inspection that all the requirements in [Clauses 4](#) and [5](#) are met. The manufacturer shall keep the record of the product inspection.

## 7 Designation

**7.1** Ladders conforming to this document shall be designated by the following indications, in the order given:

- a) Name: "Pilot ladder ISO 799-1";
- b) "S" followed by the number of steps (see [Table 1](#)); and
- c) "L" followed by the length of the securing rope of the ladder, in meters.

**EXAMPLE** The designation for a pilot ladder consisting of 15 steps with the securing rope of a length of 5 m, conforming to this document, is:

"Pilot ladder ISO 799-1-S15-L5"

**7.2** Spare or additional components for ladders conforming to this document shall be designated by reference to this document.

**EXAMPLE** The designation of a replacement step for a ladder conforming to this document is:

"Step ISO 799-1"

## 8 Marking

**8.1** The bottom of the top step and bottom of the lowest spreader step of the ladder shall be marked with:

- a) the name and address of the manufacturer;
- b) the manufacturer's model designation;
- c) "ISO 799-1" and "SOLAS";
- d) the year of assembly or reassembly of the ladder;
- e) identification of the approved maritime safety administration, along with any approval indications required by that administration, and
- f) where used, identification of an approved organization acting on behalf of the maritime safety administration.

**8.2** The bottom of each replacement step shall be marked with:

- a) the name and address of the manufacturer;
- b) the manufacturer's model designation;
- c) the words "REPLACEMENT STEP ONLY";
- d) "ISO 799-1" and "SOLAS";
- e) the year of production of the step;
- f) identification of the approved maritime safety administration, along with any approval indications required by that administration; and
- g) where used, identification of an approved organization acting on behalf of the maritime safety administration.

## 9 Production tests and examinations

Production tests and examinations of pilot ladders approved as being in accordance with this document shall be carried out as described in [Annex A](#).

## 10 Maintenance

**10.1** Damaged steps shall be replaced with replacement steps meeting the relevant requirements in [Clause 4](#) and of the type supplied or specified by the ladder manufacturer. A ladder shall not include more than two replacement steps and one replacement spreader step.

**10.2** If a ladder requires a third replacement step or a second replacement spreader step, it shall be rebuilt. A ladder constructed with spun-polyester side ropes, with the inner core showing at any place throughout the length of the ladder is no longer serviceable, and such ladder shall be rebuilt. If at any time a ladder is shown to be worn or damaged such that its strength and usability are compromised, such ladder shall be rebuilt.

**10.3** Such ladders shall be rebuilt by the original manufacturer or an organization or person authorized by the original manufacturer. The ladder shall be rebuilt according to the original manufacturer's standard, using new side ropes, and using undamaged steps in place of all damaged steps and replacement steps. In addition, there shall be two steps and one spreader step for replacement according to the relevant requirements in [Clause 5](#).

**10.4** Each ladder shall be subjected to the ladder and step attachment strength test in [Table 2](#) at not more than 30-month intervals. Each ladder which fails the test shall be rebuilt according to [10.3](#), or scrapped. The ladder shall be marked with the date of the test and the identification of the person or company performing the test. This marking shall be placed on the same steps as marking required by [8.1](#) of this document.

**10.5** Major repairs shall be undertaken by the manufacturer or manufacturer's authorized entity. Major repairs shall include repair or replacement of steps and side ropes.

## Annex A (normative)

### Production tests and inspections

#### A.1 General

The manufacturer should have a quality assurance system in place that is acceptable to the approving maritime safety administration, to ensure that production ladders are produced according to the same standard as the original prototype ladder tested for approval.

#### A.2 Sample selection and testing of steps

Steps should be separated into lots of 100 steps or less. Steps of different types should be in separate lots. One step from each lot, selected at random, should be subjected to the step strength test described in [Table A.1](#). If the step fails the test, ten more steps should be selected at random from the lot and tested as described in [Table A.1](#). If any of the ten steps fails the test, each step in the lot should be tested before it is used in a ladder.

**Table A.1 — Production tests**

| Test                                | Item to be tested                        | Test procedure   | Acceptance criteria  |
|-------------------------------------|--|--|--|
| Step strength                       | Ladder step.                             | Place supports under each end of the step where the side ropes pass through the step. Apply a static load of 8,8 kN widely distributed over a 100 mm wide area at the centre of the step.  | The step shall not break or crack.   |
| Ladder and step attachment strength | Fully assembled ladder at least 3 m long | Suspend the ladder vertically hanging to its full length, or extend the ladder to its full length on a horizontal surface, with the top end of the ladder secured using its own attachments. Apply a static load of 8,8 kN widely distributed over the bottom step for a period of at least 1 min, so that the load is applied evenly between the side ropes through the step attachment fittings. | The step shall not break or crack.<br>Attachments between any step and a side rope shall not loosen or break.<br>Side ropes shall not sustain any observable damage, elongation, or deformation that remains after the test load is removed. |

#### A.3 Sample selection and testing of ladders

The maritime safety administration, or an approved organization acting on its behalf, that approves the ladder, should conduct a visual examination as described in [Table 2](#), as well as the other tests described in [Table A.1](#), at least annually of a ladder taken from the production line to ensure that it meets the requirements of [Clauses 4](#) and [5](#) of this document.

**DS/ISO 799-1:2019**  
**ISO 799-1:2019(EN)**

---

---

**ICS 47.020.50**